

DESCRIPTION

This **TOTALPAC®X** integrated fire protection system by FireFlex Systems Inc. consists of a multicycling Firecycle® III deluge system trim totally pre-assembled, pre-wired and factory tested. All electrical and mechanical components of the system are contained in one single unit

TOTALPAC®X multicycling wet systems are built around the Viking trim using flow control valves model H-3 for 1½" (40 mm) diameter and model H-1 for 2" (50 mm) diameter and up.

The Firecycle® III wet system uses closed automatic sprinklers in the sprinkler piping. A detection network is used in parallel with the closed automatic sprinklers system. This network is electric and may be actuated by manual and rate-compensated temperature. When the detection system operates it gives an alarm and activates the Flow Control valve. Firecycle® III wet system is designed to operate as a regular wet pipe system with the ability to sense when the fire has been controlled.

In addition to automatically detecting a fire and turning the system on, Firecycle® III has the added ability to sense when the fire has been controlled, and automatically turn off the water flow once a preprogrammed "Soak Timer" has been satisfied. Should the fire rekindle, the control panel (supplied by others) will initiate the sequence again. This unique Firecycle® III feature will repeat as long as power is available to the panel, helping to minimize water usage, water damage, and the danger of pollution to surrounding areas.

The Firecycle® III deluge system requires a VIKING VFR-400 control panel (supplied by others).

All the valves are rated up to a maximum of 250 psi WWP (1724 kPa) max. and are available in the following diameters:

- 1½" (40 mm)
- 2" (50 mm)
- 3" (80 mm)
- 4" (100 mm)
- 6" (150 mm)

Standard features

- NEMA 3 or NEMA 4 construction
- Factory assembled and tested under ISO-9001 standards
- Prewired to a terminal block
- Easy and compact installation
- Viking conventional trim rated at 250 psi (1724 kPa)
- Galvanized trim piping
- Serial number for easy reference
- Wide door for easy access
- Quarter turn door latches
- Lockable door to protect against tampering
- Lifting lugs provided for safe and easy handling
- Corrosion resistant paint finish
- Water supply and drain through the bottom center of the unit to avoid freeze-up potential
- Single drain connection

Cabinet

NEMA 3

Enclosures constructed for either indoor or outdoor use to provide a degree of protection of the equipment inside the enclosure against ingress of solid foreign objects (falling dirt and windblown dust); to provide a degree of protection with respect to harmful effects on the equipment due to the ingress of water (rain, sleet, snow); and that will be undamaged by the external formation of ice on the enclosure.

NEMA 4

Enclosures constructed for either indoor or outdoor use to provide a degree of protection of the equipment inside the enclosure against ingress of solid foreign objects (falling dirt and windblown dust); to provide a degree of protection with respect to harmful effects on the equipment due to the ingress of water (rain, sleet, snow, splashing water, and hose directed water); and that will be undamaged by the external formation of ice on the enclosure.

NEMA 3X

Enclosures constructed for either indoor or outdoor use to provide a degree of protection of the equipment inside the enclosure against ingress of solid foreign objects (falling dirt and windblown dust); to provide a degree of protection with respect to harmful effects on the equipment due to the ingress of water (rain, sleet, snow); that provides an additional level of protection against corrosion and that will be undamaged by the external formation of ice on the enclosure.

NEMA 4X

Enclosures constructed for either indoor or outdoor use to provide a degree of protection of the equipment inside the enclosure against ingress of solid foreign objects (windblown dust); to provide a degree of protection with respect to harmful effects on the equipment due to the ingress of water (rain, sleet, snow, splashing water, and hose directed water); that provides an additional level of protection against corrosion; and that will be undamaged by the external formation of ice on the enclosure.

COMPARISON OF SPECIFIC NON-HAZARDOUS APPLICATIONS

Provide a degree of protection against the following environmental conditions	Type of enclosure			
	3 ^a	3X ^a	4	4X
Incidental contact with enclosed equipment	•	•	•	•
Rain, snow and sleet	•	•	•	•
Hose down and splashing water			•	•
Corrosive agents		•		•
Ingress of solid foreign object (circulating or setting airborne dust, lint, fibers, and flyings) ^b			•	•
Ingress of solid foreign objects (winblown dust, lint, fibers, and flyings) ^b	•	•	•	•

^a : these cabinet may be ventilated.

^b : these fibers and flyings are non hazardous materials and are not considered class III type ignitable fibers or combustible flyings.

Sequence of operation (see trim diagram)

In a fire condition, when the detection condition is satisfied, system control panel (supplied by others) activates an alarm and energizes normally closed Solenoid valve (F2) open and normally open solenoid valve (F1) closed. Pressure is released from the priming chamber of the flow control valve (A1) to the open drain manifold faster than it is supplied through the restricted orifice (B3). The flow control valve clapper opens to allow water to flow into the system piping and alarm devices, causing the alarm water flow switch (C3) to activate. Water will flow from all the open sprinklers in the system. When the flow control valve operates, the PORV (B9) is pressurized, causing it to latch open. Water discharges until all Firecycle® detectors have reset (cooled below their set point). After all detectors have reset, the Firecycle® III control panel activates the soak timer, allowing the system to flow water for a pre-determined period of time. When the soak timer has elapsed, the control panel de-energizes the normally closed solenoid valve (F2), allowing it to close, the normally open solenoid (F1) remains energized closed until the system is manually reset or all power (both AC and batteries) is lost). The flow control valve re-primed and closes, stopping the flow of water through the piping system. Should a Firecycle® detector go into alarm, the control panel reenergizes the normally closed solenoid valve (F2) open, and the entire cycle repeats.

Systems hydraulic limitations

WARNING The information contained herewith is for estimation and evaluation purposes only. Its use remains the responsibility of the designer.

Designers should refer to the appropriate NFPA Standards and any other applicable codes for their final design. Also refer to FireFlex Systems Inc. appropriate user manuals and to manufacturer's data sheets for additional details. Systems limitations indicated below are nominal flow limitations.

System size (in.)	Usage Range (gpm)	Piping Equivalent Lengths w/o shut off valve	
		(m.)	(ft.)
1½	0 – 200	8.1	26.6
2	0 – 330	11.3	37
3	125 - 700	17.7	58.2
4	250 – 1200	24	79
6	750 - 2800	26	85.4

Standard equipment

Flow control valve

The Viking flow control valve is a quick opening, differential type flood valve with a spring loaded rolling diaphragm clapper. The flow control valve can be used to facilitate manual or automatic on/off control. As an on/off control valve it may be used on deluge systems. The Viking flow control valve is an integral part of the Viking Firecycle® System.

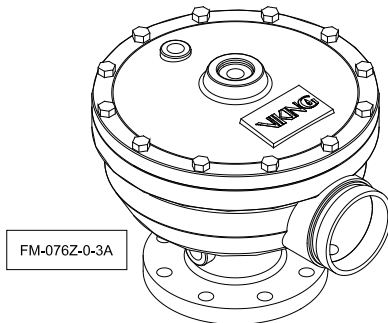

Solenoid valve

The high pressure solenoid valve is a two-way type with one inlet and one outlet. It is a packless, internal pilot operated valve, suitable for use in releasing water pressure from the priming chamber of Viking deluge valves. The solenoid valve has floating diaphragm construction, which requires a minimum pressure drop across the valve to operate properly.

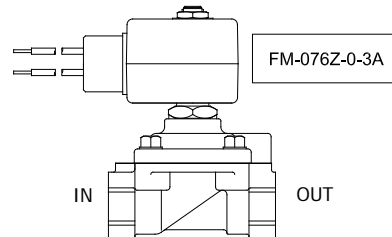

Water supply control valve

The water inlet control valve is a supervised, indicating butterfly valve. Purpose of this valve is to manually shutoff the preaction system.

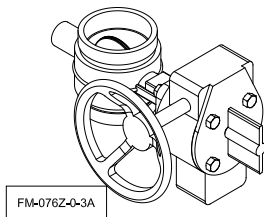

Alarm water flow switch

The alarm water flow switch monitors the water flow within the sprinkler piping. Should an automatic sprinkler open to allow water to flow into the sprinkler piping. The alarm water flow switch will activate, indicating a water flow signal.

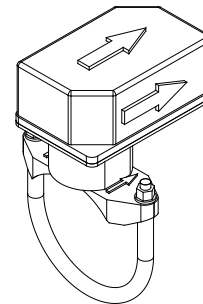

Optional equipment

Shut-off valve & sight glass option

The Shut-off Valve & Sight Glass Option is intended to be used for applications where testing of the system operation without filling the sprinkler piping network is desirable and where it is critical that all functions of the preaction system be tested under actual discharge conditions.

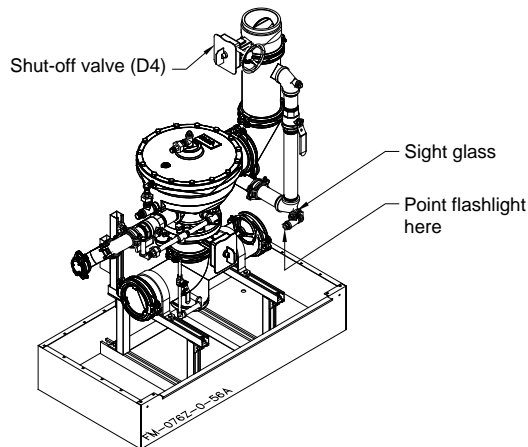

Heater option

Heater option is recommended where ambient temperatures can drop below 40°F (4.5°C). The cabinet's electric heater temperature cut-out point is set at 50°F (10°C). The heater option is equipped with a low temperature sensor that will activate a supervisory signal when temperature drops below 40°±5°F (4.5°±3°C).

Heater option can be ordered in two supply voltage settings:

- 120Vac-60Hz. 400Watts.
- 220Vac-50Hz. 400Watts.

Warning: TOTALPAC®X cabinet is rated to provide freeze protection down to a minimum temperature of 14°F (-10°C).

Insulated enclosure (standard with heater option)

Insulation is made on foam core 2" thick R13 and have a foil-faced sheathing board composed of a uniform closed cell polyisocyanurate foam core bonded on each side to a triminate foil facer. One side has a foil reflective facer and the other side has a non-reflective foil facer.

Low temperature sensor (standard with heater option)

The low temperature sensor will close the normally open contact when the temperature drops below 40°F (4,5°C). The sensor will automatically reset to its normal state when the temperature rises above 40°F (4,5°C).

Light option

Optional fluorescent enclosure light is available for all cabinet configurations. Remote door switch activates the light when the door is opened.

Light option can be ordered in two supply voltage settings:

- 120Vac-60Hz.
- 220Vac-50Hz.

Details & field wiring diagrams

Cabinet with main components, shown without door

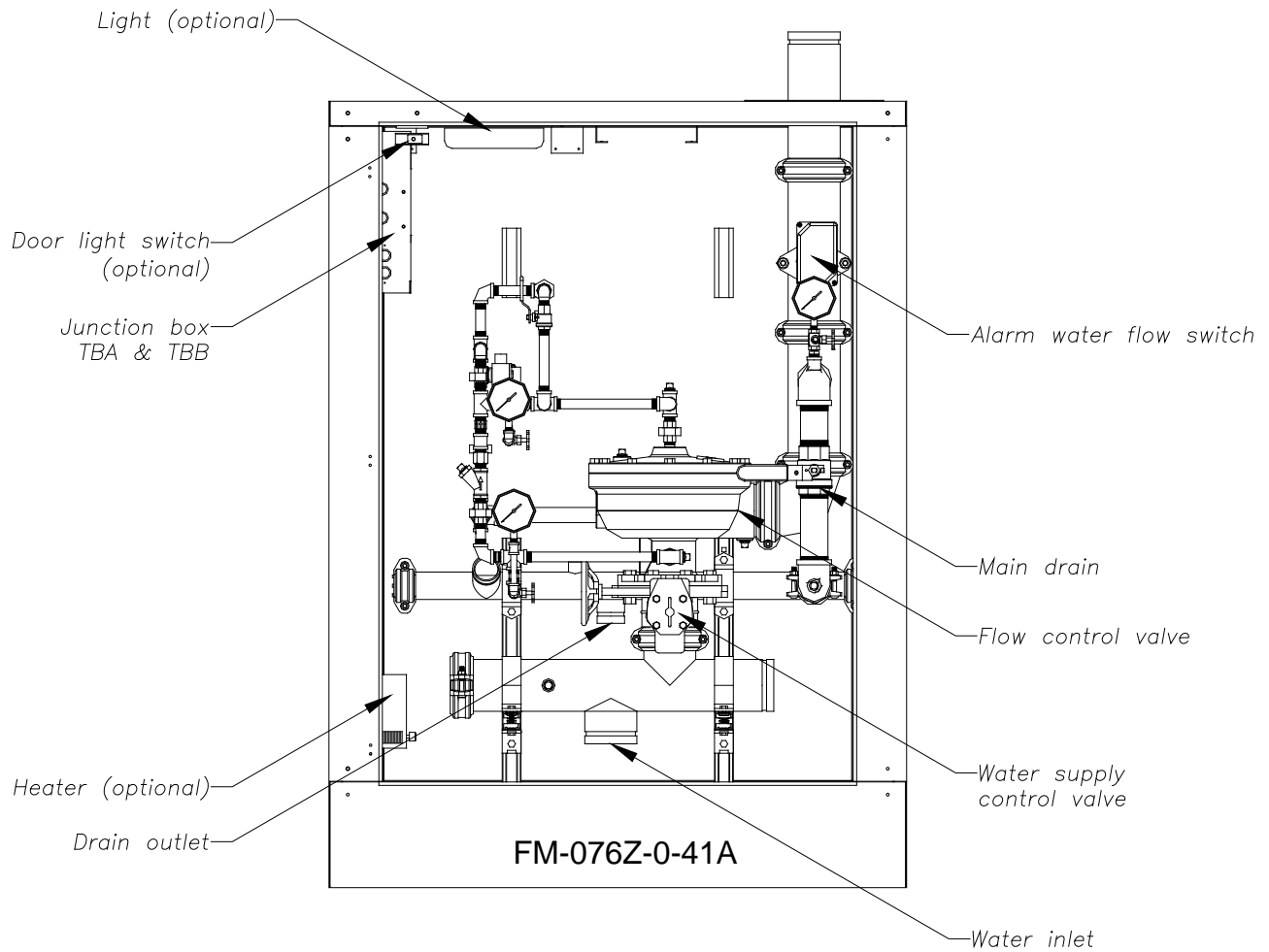

Trim diagram

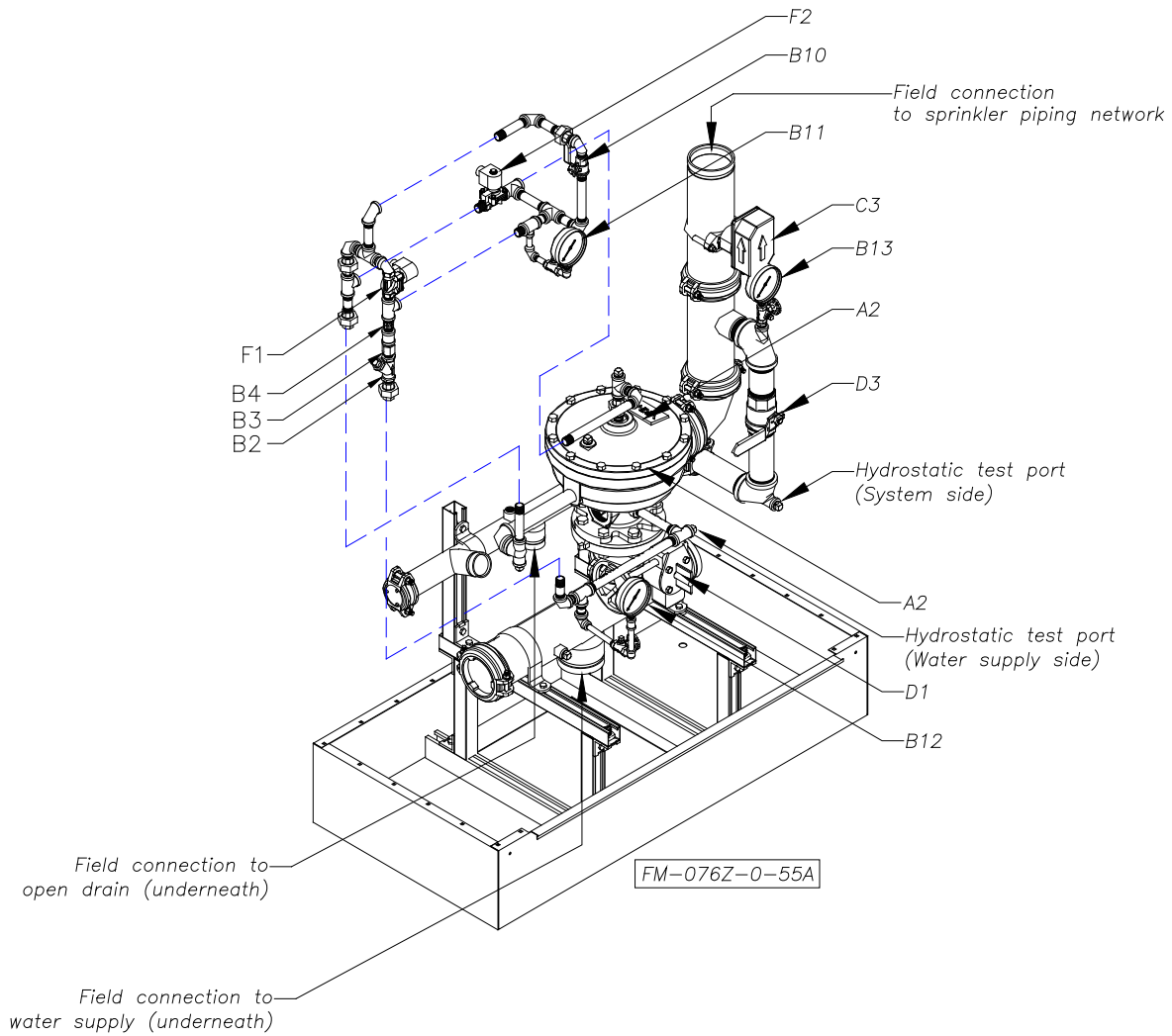

Components:

- | | | | |
|-----|---------------------------------------|----|----------------------------|
| A2 | Flow control valve | C3 | Alarm water flow switch |
| B1 | Priming valve | D1 | Water supply control valve |
| B2 | Strainer | D3 | Main drain valve |
| B3 | 1/8" Restricted orifice | F1 | N.O Solenoid Valve – 24Vdc |
| B4 | Spring loaded check valve | F2 | N.C Solenoid Valve – 24Vdc |
| B5 | Alarm test valve | | |
| B6 | Flow test valve | | |
| B7 | Drip check valve | | |
| B8 | Drain check valve | | |
| B9 | Pressure operated relief valve (PORV) | | |
| B10 | Emergency release valve | | |
| B11 | Priming pressure water gauge & valve | | |
| B12 | Water supply pressure gauge & valve | | |
| B13 | Clapper check valve | | |

Wiring diagram

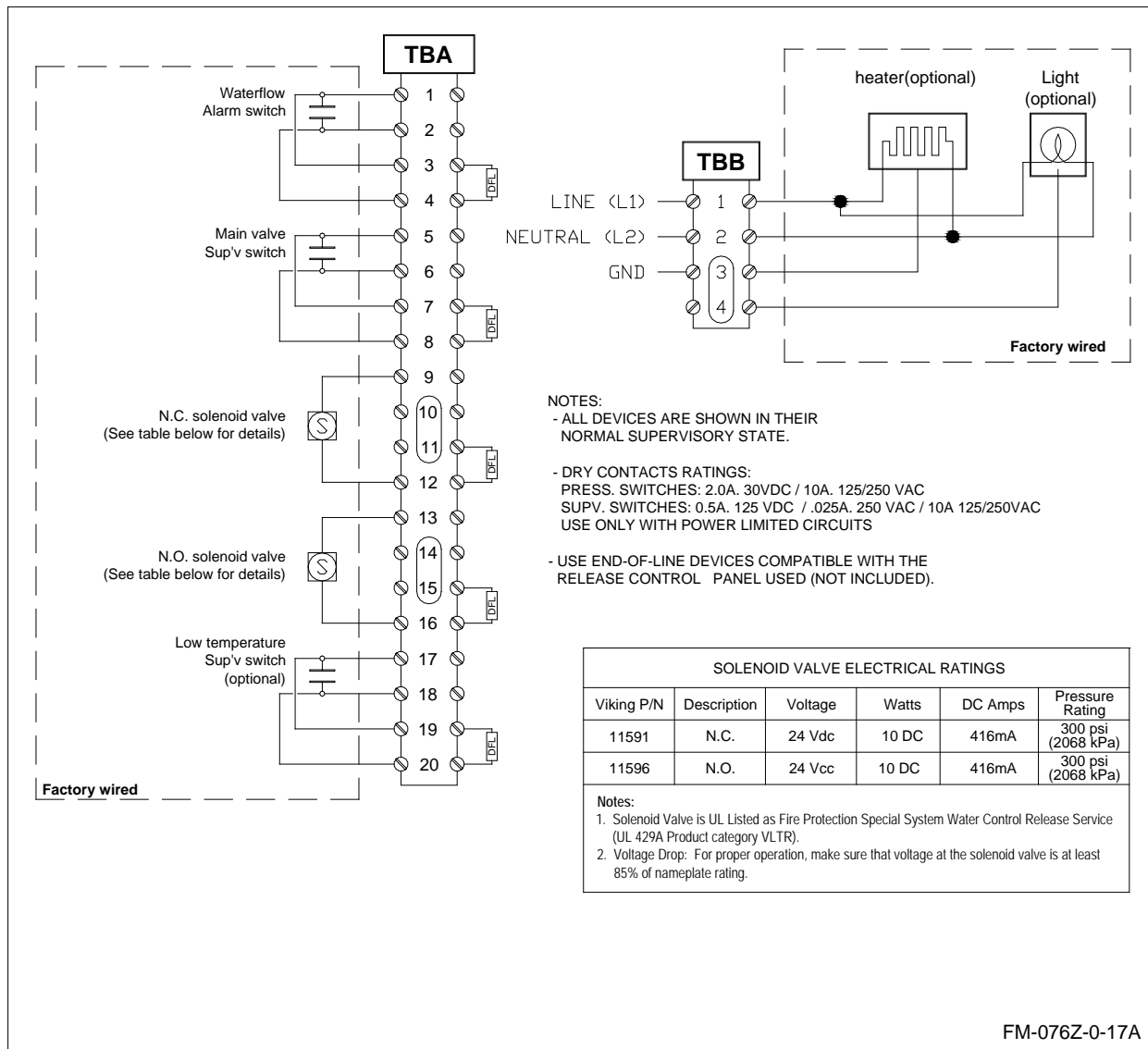

Dimensions

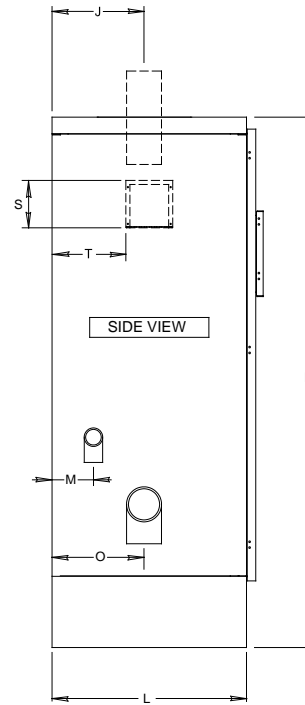
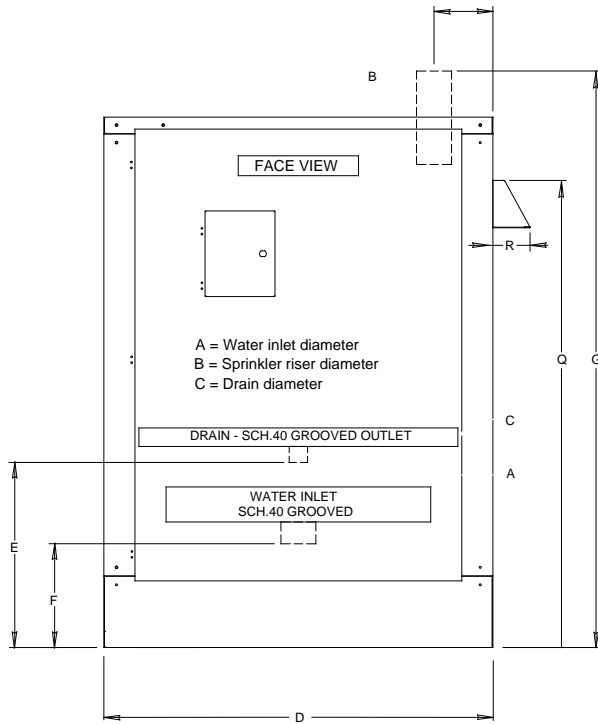

FM-076Z-0-54B

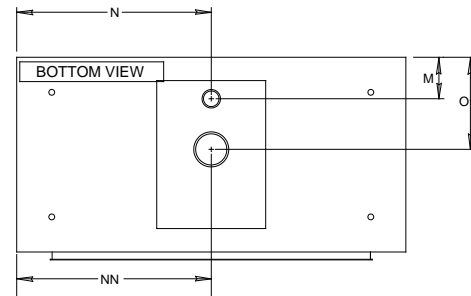
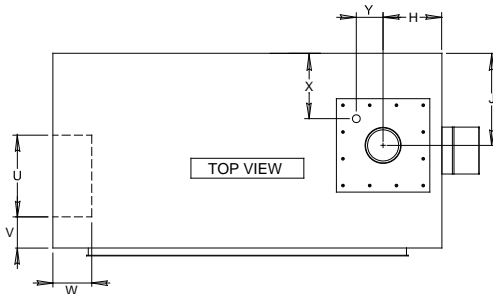

Dimensions are nominal and may vary $\pm 1/4"$.

Size	A	B	C	D	E	F	G	H	J	K	L	M	N	NN	O	Q	R	S	T	U	V	W	X	Y
1.5"	2"	1.5"	2"	50"	24.5"	14.5"	74"	11.5"	11"	68"	25"	5.5"	25"	25"	11"	60"	4.75"	6"	9.5"	10.5"	4"	5"	9.5"	7.75"
2"	2"	2"	2"	50"	23"	12"	74"	12"	11"	68"	25"	5"	25"	25"	11"	60"	4.75"	6"	9.5"	10.5"	4"	5"	9.5"	8"
3"	4"	3"	2"	50"	23"	12.5"	74"	8.5"	11"	68"	25"	5.5"	28.5"	22"	11"	60"	4.75"	6"	9.5"	10.5"	4"	5"	9.5"	8.5"
4"	4"	4"	2"	50"	22.5"	12.5"	74"	8"	12"	68"	25"	5.5"	25.5"	25.5"	12"	60"	4.75"	6"	9.5"	10.5"	4"	5"	9.5"	9"
6"	6"	6"	2"	50"	21"	12"	74"	8"	12"	68"	25"	5"	25"	25"	12"	60"	4.75"	6"	9.5"	10.5"	4"	5"	9.5"	9"

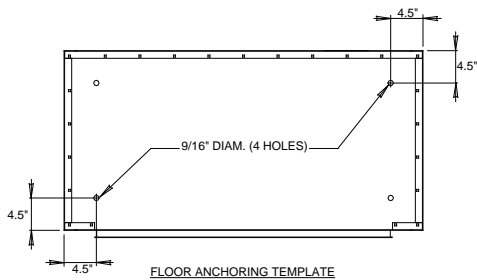



ADVANCED INTEGRATED FIRE PROTECTION SYSTEMS

1935, Lionel-Bertrand Blvd.
Boisbriand QC Canada J7H 1N8
Tel.: 450-437-3473 • Fax: 450-437-1930
Toll Free: 866-347-3353

Email: info@fireflex.com • Web: www.fireflex.com