



*DESCRIPTION*

This **TOTALPAC®X** integrated fire protection system by FireFlex Systems Inc. consists of a deluge system trim totally pre-assembled, pre-wired and factory tested. All electrical and mechanical components of the system are contained in one single unit

**TOTALPAC®X** deluge systems are built around the Viking trim using deluge valves model E-3 for 1½" (40 mm) diameter and model E-1 for 2" (50 mm) diameter and up.

Pneumatically controlled deluge systems require a pneumatic release system, equipped with fixed temperature releases, and/or pilot heads.

Release trim, for pneumatically controlled deluge systems utilize a Pneumatic Actuator normally held closed by pressure maintained in the pneumatic release system.

In fire conditions, operation of the pneumatic release system opens the Deluge Valve, allowing water to enter the system piping. Water will flow from any open sprinklers and/or spray nozzles on the system.

**Note:** The air supply for the pneumatic release piping system must be provided by the contractor and installed outside the **TOTALPACX** unit. **The air supply must be restricted** to ensure that the automatic air supply cannot replace air as fast as it escapes when a releasing device or sprinkler operates. It is also recommended to provide Inspectors Test Connections on both the release system and the sprinkler system.

All the valves are rated up to a maximum of 250 psi WWP (1724 kPa) max. and are available in the following diameters:

- 1½" (40 mm)
- 2" (50 mm)
- 3" (80 mm)
- 4" (100 mm)
- 6" (150 mm)

*Standard features*

- NEMA 3 or NEMA 4 construction
- Factory assembled and tested under ISO-9001 standards
- Prewired to a terminal block
- Easy and compact installation
- Viking conventional trim rated at 250 psi (1724 kPa)
- Galvanized trim piping
- Serial number for easy reference
- Wide door for easy access
- Quarter turn door latches
- Lockable door to protect against tampering
- Lifting lugs provided for safe and easy handling
- Corrosion resistant paint finish
- Water supply and drain through the bottom center of the unit to avoid freeze-up potential
- Single drain connection

*Cabinet*

NEMA 3

Enclosures constructed for either indoor or outdoor use to provide a degree of protection of the equipment inside the enclosure against ingress of solid foreign objects (falling dirt and windblown dust); to provide a degree of protection with respect to harmful effects on the equipment due to the ingress of water (rain, sleet, snow); and that will be undamaged by the external formation of ice on the enclosure.

NEMA 4

Enclosures constructed for either indoor or outdoor use to provide a degree of protection of the equipment inside the enclosure against ingress of solid foreign objects (falling dirt and windblown dust); to provide a degree of protection with respect to harmful effects on the equipment due to the ingress of water (rain, sleet, snow, splashing water, and hose directed water); and that will be undamaged by the external formation of ice on the enclosure.

NEMA 3X

Enclosures constructed for either indoor or outdoor use to provide a degree of protection of the equipment inside the enclosure against ingress of solid foreign objects (falling dirt and windblown dust); to provide a degree of protection with respect to harmful effects on the equipment due to the ingress of water (rain, sleet, snow); that provides an additional level of protection against corrosion and that will be undamaged by the external formation of ice on the enclosure.

NEMA 4X

Enclosures constructed for either indoor or outdoor use to provide a degree of protection of the equipment inside the enclosure against ingress of solid foreign objects (windblown dust); to provide a degree of protection with respect to harmful effects on the equipment due to the ingress of water (rain, sleet, snow, splashing water, and hose directed water); that provides an additional level of protection against corrosion; and that will be undamaged by the external formation of ice on the enclosure.

**COMPARISON OF SPECIFIC NON-HAZARDOUS APPLICATIONS**

Provide a degree of protection against the following environmental conditions	Type of enclosure			
	3 <sup>a</sup>	3X <sup>a</sup>	4	4X
Incidental contact with enclosed equipment	•	•	•	•
Rain, snow and sleet	•	•	•	•
Hose down and splashing water			•	•
Corrosive agents		•		•
Ingress of solid foreign object (circulating or setting airborne dust, lint, fibers, and flyings) <sup>b</sup>			•	•
Ingress of solid foreign objects (winblown dust, lint, fibers, and flyings) <sup>b</sup>	•	•	•	•

<sup>a</sup> : these cabinet may be ventilated.

<sup>b</sup> : these fibers and flyings are non hazardous materials and are not considered class III type ignitable fibers or combustible flyings.

*Sequence of operation (see trim diagram)*

In a fire condition, when a releasing device operates, pressure in the pneumatic release system escapes causing the pneumatic actuator (F3) to open.

Pressure is released from the priming chamber of the deluge valve (A1) to the open drain manifold faster than it is supplied through the restricted orifice (B3). The Deluge Valve clapper opens to allow water to flow into the system piping and alarm devices, causing the alarm pressure switch (C1) and optional water motor alarm (C2) to activate. Water will flow from all the open sprinklers and/or nozzles in the system.

When the deluge valve operates, the sensing end of the PORV (B9) is pressurized, causing the PORV to open. When the PORV opens, it drains the priming water pressure to the priming chamber, preventing the deluge valve (A1) from resetting, even if the open releasing devices close. The deluge valve can only be reset after the system is taken out of service, and the outlet chamber of the deluge valve and associated trim piping is depressurized and drained.

*Systems hydraulic limitations*

**WARNING** The information contained herewith is for estimation and evaluation purposes only. Its use remains the responsibility of the designer.

Designers should refer to the appropriate NFPA Standards and any other applicable codes for their final design. Also refer to FireFlex Systems Inc. appropriate user manuals and to manufacturer's data sheets for additional details.

Systems limitations indicated below are nominal flow limitations.

System size (in.)	Usage Range (gpm)	Piping Equivalent Lengths w/o shut off valve	
		(m.)	(ft.)
1½	0 – 200	7.4	24.2
2	0 – 330	10.9	35.8
3	125 - 700	17.2	56.3
4	250 – 1200	23	75.6
6	750 - 2800	25.1	82.4

*Standard equipment*

**Deluge valve**

The Viking Model deluge valve is a quick-opening, differential diaphragm, flood valve with one moving mechanism. The deluge valve is used to control water flow in deluge and preaction sprinkler systems. The valve is held closed by system water pressure trapped in the priming chamber, keeping the outlet chamber and system piping dry. In fire conditions, when the releasing system operates, pressure is released from the priming chamber. The deluge valve clapper opens to allow water to flow into the system piping.

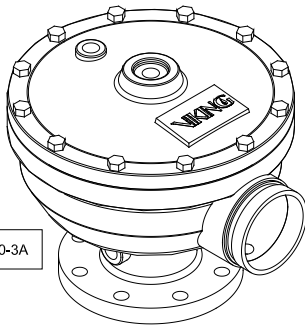

FM-076Z-0-3A

**Water supply control valve**

The water inlet control valve is a supervised, indicating butterfly valve. Purpose of this valve is to manually shutoff the preaction system.

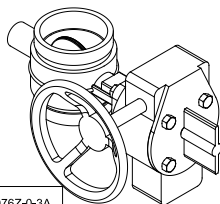

FM-076Z-0-3A

**Pneumatic actuator**

Used in conjunction with the solenoid valve, the Viking Pneumatic Actuator is a spring loaded, rolling diaphragm and piston operated valve. It is used wherever a combination is required between the detection and system's loss of air.

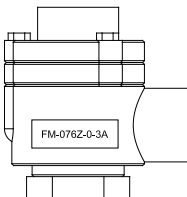

FM-076Z-0-3A

**Alarm pressure switch**

The alarm pressure switch monitors the water flow within the sprinkler piping. Should the Deluge Valve clapper opens to allow water to flow into the sprinkler piping. The alarm pressure switch will activate, indicating a water flow signal.

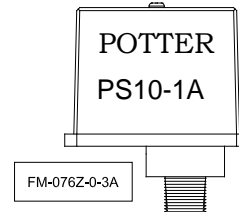

FM-076Z-0-3A

**Low air supervisory switch**

The low pressure switches monitors the pressure within the pneumatic release system pneumatic release system should a loss pressure of the air below 12PSI occurs. The pressure switch contacts transfer indicating supervisory signal.

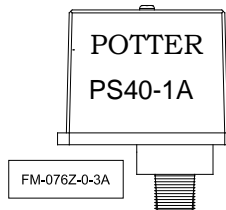

FM-076Z-0-3A

### Optional equipment

#### Shut-off valve & sight glass option

The Shut-off Valve & Sight Glass Option is intended to be used for applications where testing of the system operation without filling the sprinkler piping network is desirable and where it is critical that all functions of the preaction system be tested under actual discharge conditions.

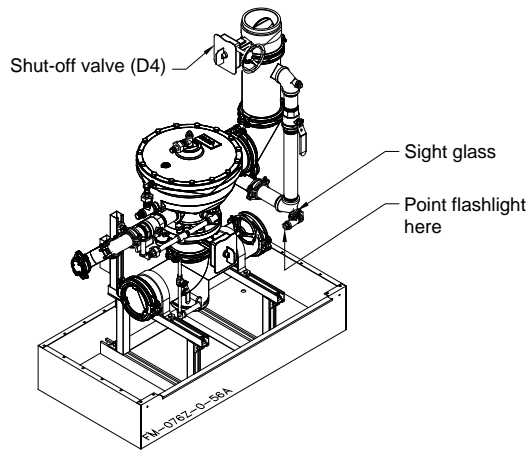

#### Heater option

Heater option is recommended where ambient temperatures can drop below 40°F (4.5°C). The cabinet's electric heater temperature cut-out point is set at 50°F (10°C). The heater option is equipped with a low temperature sensor that will activate a supervisory signal when temperature drops below 40°±5°F (4.5°±3°C).

Heater option can be ordered in two supply voltage settings:

- 120Vac-60Hz. 400Watts.
- 220Vac-50Hz. 400Watts.

**Warning: TOTALPAC®X cabinet is rated to provide freeze protection down to a minimum temperature of 14°F (-10°C).**

#### Insulated enclosure (standard with heater option)

Insulation is made on foam core 2" thick R13 and have a foil-faced sheathing board composed of a uniform closed cell polyisocyanurate foam core bonded on each side to a triminate foil facer. One side has a foil reflective facer and the other side has a non-reflective foil facer.

#### Low temperature sensor (standard with heater option)

The low temperature sensor will close the normally open contact when the temperature drops below 40°F (4,5°C). The sensor will automatically reset to its normal state when the temperature rises above 40°F (4,5°C).

#### Light option

Optional fluorescent enclosure light is available for all cabinet configurations. Remote door switch activates the light when the door is opened.

Light option can be ordered in two supply voltage settings:

- 120Vac-60Hz.
- 220Vac-50Hz.

## Air supply

### **Air Pressure Maintenance Device** (Style "C")

Used only for the pneumatic release piping network of pneumatically operated Preaction or deluge systems. An external air supply has to be provided by others (compressor, plant air or dry nitrogen cylinders) and piped to the air inlet port of the unit. Air supply style "C" provides an air pressure maintenance device (APMD) trim, factory mounted in the **TOTALPAC®X** cabinet.

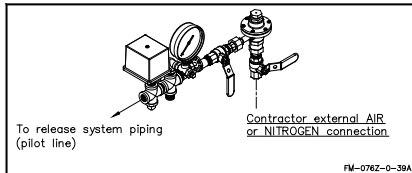

**Note:** The external air supply must be restricted to insure that it cannot replace air as fast as it escapes when a releasing device or sprinkler operates.

*Details & field wiring diagrams*

**Cabinet with main components, shown without door**

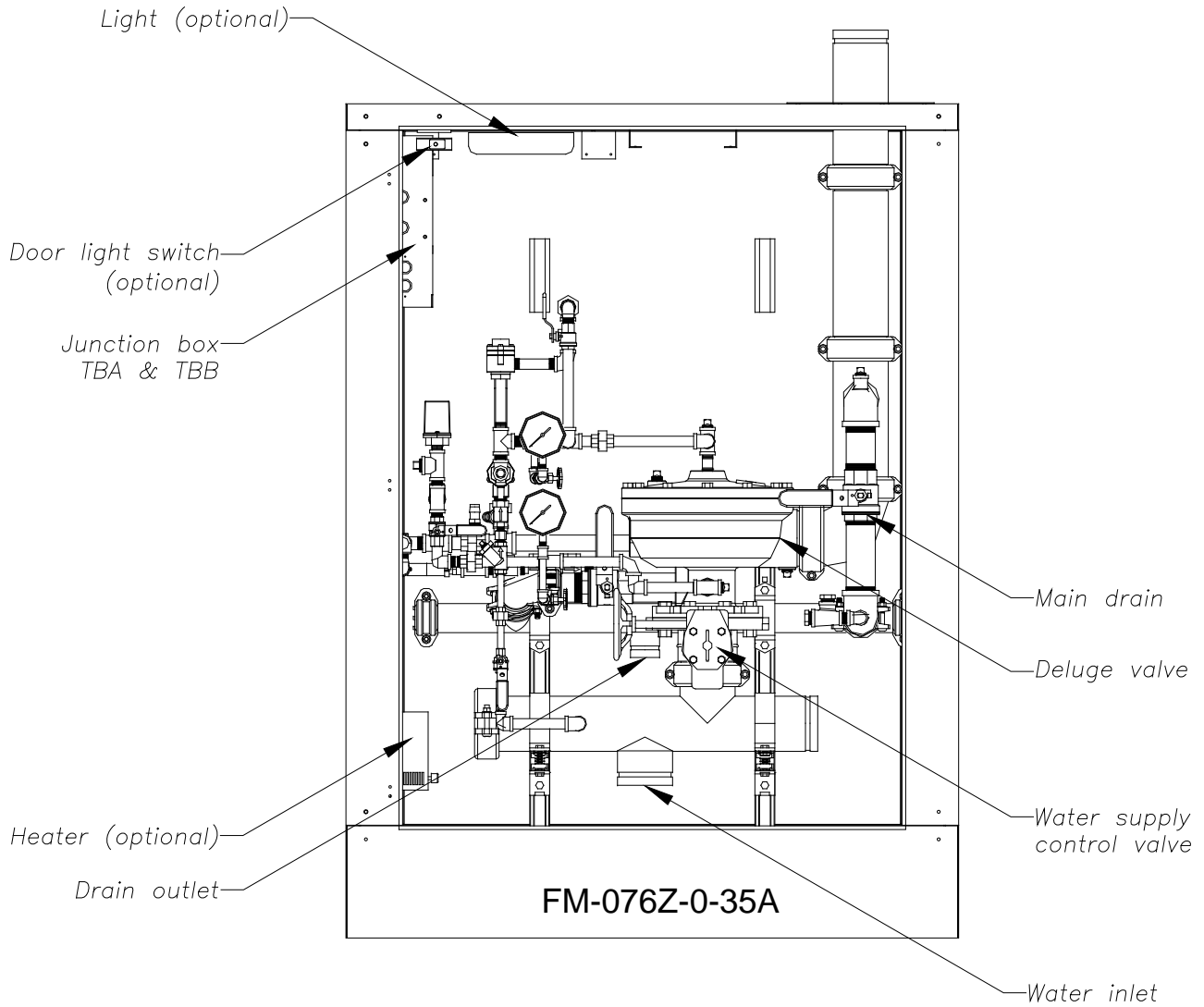

**Trim diagram**

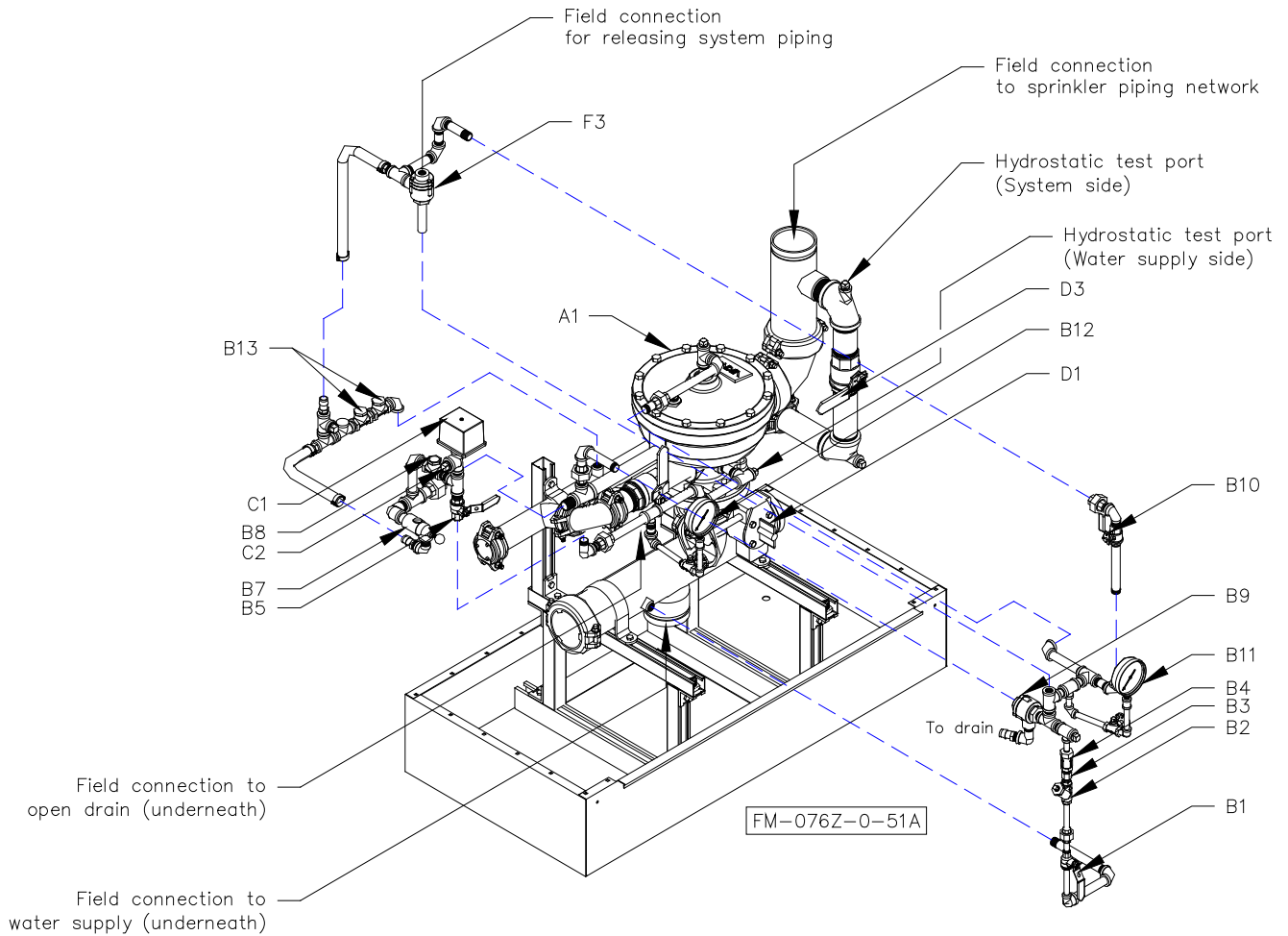

**Components:**

- |     |                                       |    |  |
|-----|---------------------------------------|----|--|
| A1  | Deluge valve                          | C1 | Alarm pressure switch  |
| B1  | Priming valve                         | C2 | Connection to water motor gong (strainer supplied by contractor) |
| B2  | Strainer                              | D1 | Water supply control valve                                       |
| B3  | 1/16" Restricted orifice              | D3 | Main drain valve   |
| B4  | Spring loaded check valve             | F3 | Pneumatic Actuator   |
| B5  | Alarm test valve                      |    |  |
| B6  | Flow test valve                       |    |  |
| B7  | Drip check valve                      |    |  |
| B8  | Drain check valve                     |    |  |
| B9  | Pressure operated relief valve (PORV) |    |  |
| B10 | Emergency release valve               |    |  |
| B11 | Prime pressure water gauge & valve    |    |  |
| B12 | Water supply pressure gauge & valve   |    |  |
| B13 | Clapper check valve                   |    |  |



Wiring diagram

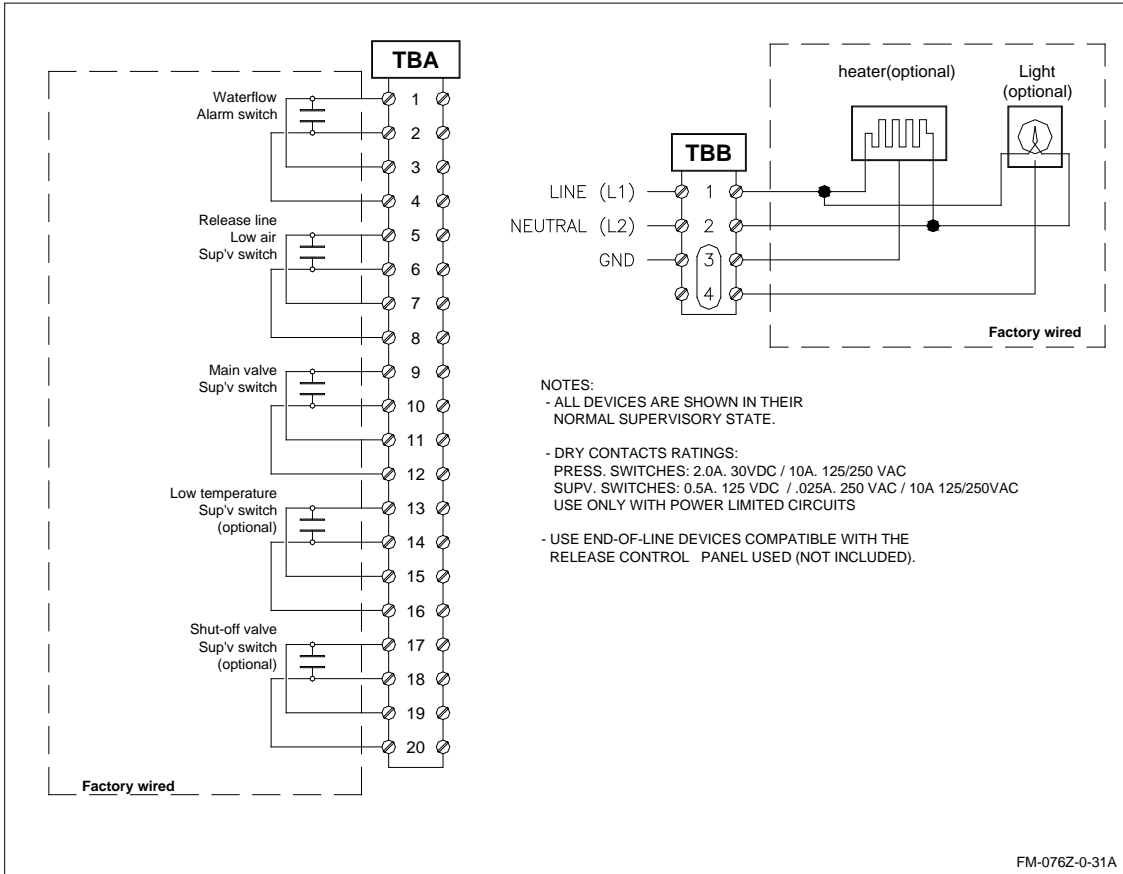

*Dimensions*

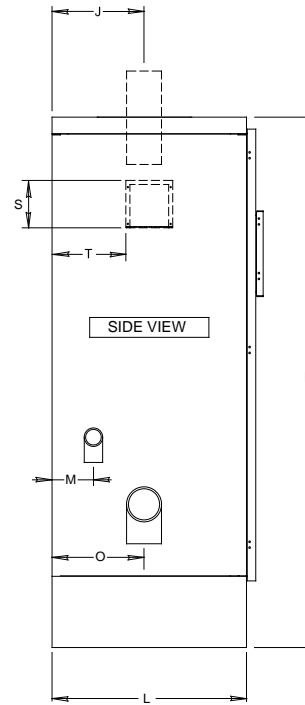
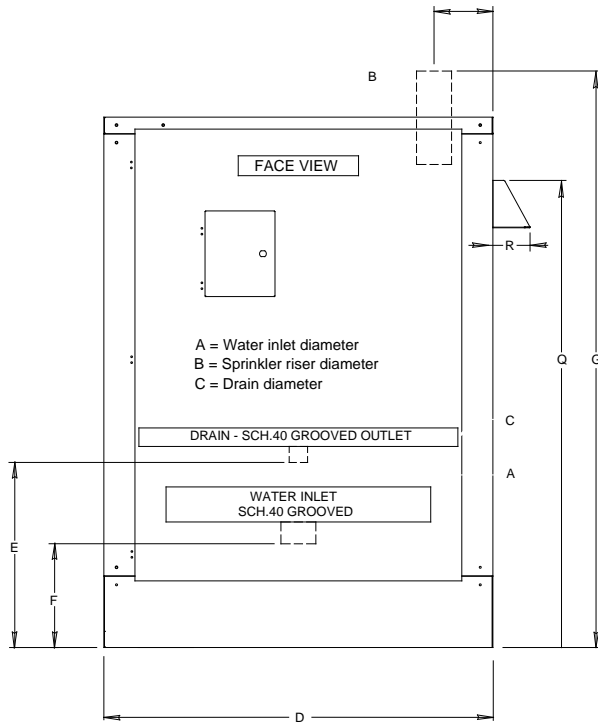

FM-076Z-0-54B

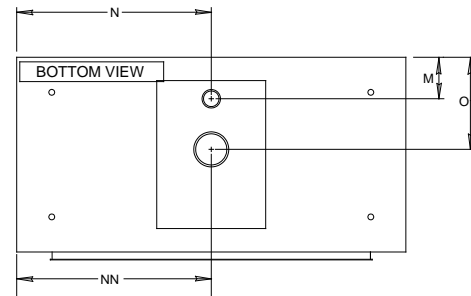
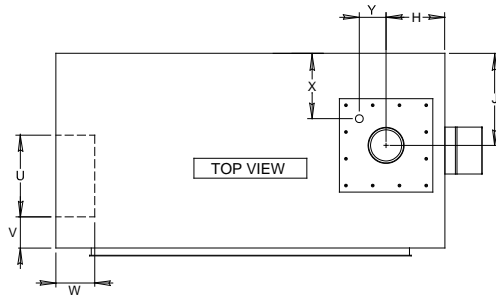

Dimensions are nominal and may vary  $\pm 1/4"$ .

Size	A	B	C	D	E	F	G	H	J	K	L	M	N	NN	O	Q	R	S	T	U	V	W	X	Y
1.5"	2"	1.5"	2"	50"	24.5"	14.5"	74"	11.5"	11"	68"	25"	5.5"	25"	25"	11"	60"	4.75"	6"	9.5"	10.5"	4"	5"	9.5"	7.75"
2"	2"	2"	2"	50"	23"	12"	74"	12"	11"	68"	25"	5"	25"	25"	11"	60"	4.75"	6"	9.5"	10.5"	4"	5"	9.5"	8"
3"	4"	3"	2"	50"	23"	12.5"	74"	8.5"	11"	68"	25"	5.5"	28.5"	22"	11"	60"	4.75"	6"	9.5"	10.5"	4"	5"	9.5"	8.5"
4"	4"	4"	2"	50"	22.5"	12.5"	74"	8"	12"	68"	25"	5.5"	25.5"	25.5"	12"	60"	4.75"	6"	9.5"	10.5"	4"	5"	9.5"	9"
6"	6"	6"	2"	50"	21"	12"	74"	8"	12"	68"	25"	5"	25"	25"	12"	60"	4.75"	6"	9.5"	10.5"	4"	5"	9.5"	9"

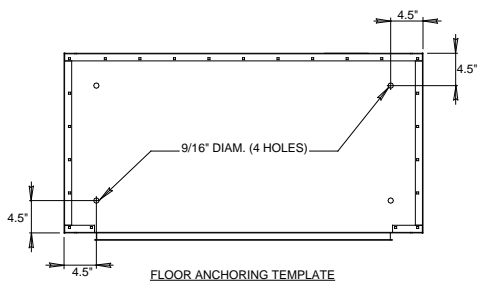



ADVANCED INTEGRATED FIRE PROTECTION SYSTEMS

TotalPac®X  
Deluge system  
Pneumatic release



**ADVANCED INTEGRATED FIRE PROTECTION SYSTEMS**

1935, Lionel-Bertrand Blvd.  
Boisbriand QC Canada J7H 1N8  
Tel.: 450-437-3473 • Fax: 450-437-1930  
Toll Free: 866-347-3353

Email: [info@fireflex.com](mailto:info@fireflex.com) • Web: [www.fireflex.com](http://www.fireflex.com)