



OSHPD (Optional)

DESCRIPTION

This **TOTALPAC®3** integrated fire protection system by FireFlex Systems Inc. consists of a deluge system trim totally pre-assembled, pre-wired and factory tested. All electrical and mechanical components of the system are contained in one single unit

TOTALPAC®3 deluge systems are built around the Viking trim using deluge valves model F-1.

Pneumatically controlled deluge systems require a pneumatic release system, equipped with fixed temperature releases, and/or pilot heads.

Release trim, for pneumatically controlled deluge systems utilize a pneumatic actuator normally held closed by pressure maintained in the pneumatic release system.

In fire conditions, operation of the pneumatic release system opens the deluge valve, allowing water to enter the system piping. Water will flow from any open sprinklers and/or spray nozzles on the system.

All the valves are rated up to a maximum of 250 psi WWP (1724 kPa) max. and are available in the following diameters:

- 1½" (40 mm) 2" (100 mm) 3" (80 mm)
 4" (100 mm) 6" (150 mm) 8" (200 mm)

Standard features

- cULus Listed & FM Approved as an assembled unit
- Factory assembled, programmed and tested under ISO-9001 standards
- Prewired to a terminal block
- Easy and compact installation
- Viking conventional trim rated at 250 psi (1724 kPa)
- Galvanized trim piping
- Serial number for easy reference
- Corrosion resistant cabinet with flush type handle and lock
- No open drain cup inside the unit
- numerous modular options to meet the most demanding jobsite requirements
- Four styles of modular air supply options
- Inlet & outlet hydrostatic test ports
- User-friendly standardized operation & installation manual
- Free interactive simulator

Cabinet

The **TOTALPAC®3** cabinets are made of sturdy 14 gauge steel, they are available in four (4) sizes;

23" x 25" x 77" (58.4 x 63.5 x 195.6 cm) for 1½", and 2" systems,

36" x 25" x 77" (91.4 x 63.5 x 195.6 cm) for 3" and 4" system,

46" x 25" x 77" (116.8 x 63.5 x 195.6 cm) for 6" system

54" x 31" x 81" (137.2 x 78.7 x 205.7 cm) for 8" system

All surfaces are rust proof coated, inside and outside, with fire red, oven baked polyester powder on phosphate base. Cabinet is provided with one or two doors, all provided with a neoprene gasket to absorb vibrations.

A field wiring electrical junction boxes is integrated with the cabinet for connection of all electrical components in the trim. Pressure switches, supervisory switches, etc. are all factory wired to a terminal strip (TBA) for contractor's field wiring.

Gauges to indicate water supply pressure and priming water pressure are all visible through clear Lexan windows.

IMPORTANT: **TOTALPAC®3** units are NOT designed to be installed where they will be subjected to outdoors and/or freezing conditions. Refer to environmental data for additional details. Subjecting the unit to conditions outside these limitations might tamper the normal operation of the system.

The cabinet assembly is pre-assembled, pre-wired, and factory tested under ISO-9001 conditions.

Multiple unit installations are easily achieved by manifolding units together at their water inlets but drains shall remain separate and open.

Sequence of operation (see trim diagram)

In a fire condition, when a releasing device operates, pressure in the pneumatic release system escapes causing the pneumatic actuator (*F3*) to open.

Pressure is released from the priming chamber of the deluge valve (*A1*) to the open drain manifold faster than it is supplied through the restricted orifice (*B3*). The Deluge Valve clapper opens to allow water to flow into the system piping and alarm devices, causing the alarm pressure switch (*C1*) and optional water motor alarm (*C2*) to activate. Water will flow from all the open sprinklers and/or nozzles in the system.

When the deluge valve operates, the sensing end of the PORV (*B9*) is pressurized, causing the PORV to open. When the PORV opens, it drains the priming water pressure to the priming chamber, preventing the deluge valve (*A1*) from resetting, even if the open releasing devices close. The deluge valve can only be reset after the system is taken out of service, and the outlet chamber of the deluge valve and associated trim piping is depressurized and drained.

Systems hydraulic limitations

WARNING The information contained herewith is for estimation and evaluation purposes only. Its use remains the responsibility of the designer.

Designers should refer to the appropriate NFPA Standards and any other applicable codes for their final design.

System size (in.)	Usage Range (gpm)	Piping Equivalent Lengths w/o shut off valve		Piping Equivalent Lengths c/w shut off valve	
		(m.)	(ft.)	(m.)	(ft.)
1½	0 – 210	6.77	22.2	6.98	22.9
2	0 – 360	9.2	30.2	9.42	30.9
3	100 - 700	13.75	45.1	17.28	56.7
4	200 – 1400	17.92	58.8	21.37	70.1
6	400 - 3500	27.17	89.15	31.18	102.3
8	750 - 5250	34.14	112.0	37.7	123.7

System drain flow:

System size	USGPM Formula
1½" & 2"	0.5 x (water pressure Psi) + 65 = USGPM
3"	1.2 x (water pressure Psi) + 130 = USGPM
4", 6" & 8"	2.7 x (water pressure Psi) + 215 = USGPM

System size	LPM Formula
1½" & 2"	2 x (water pressure Psi) + 235 = LPM
3"	4 x (water pressure Psi) + 490 = LPM
4", 6" & 8"	10 x (water pressure Psi) + 800 = LPM

Standard equipment

Deluge valve

The Viking Model deluge valve is a quick-opening, differential diaphragm, flood valve with one moving mechanism. The deluge valve is used to control water flow in deluge and preaction sprinkler systems. The valve is held closed by system water pressure trapped in the priming chamber, keeping the outlet chamber and system piping dry. In fire conditions, when the releasing system operates, pressure is released from the priming chamber. The deluge valve clapper opens to allow water to flow into the system piping.

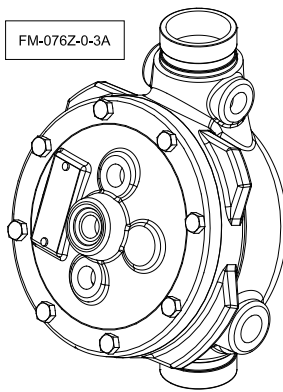

Water supply control valve

The water inlet control valve is a supervised, indicating butterfly valve. Purpose of this valve is to manually shutoff the preaction system.

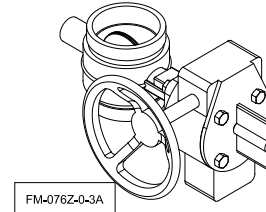

Pneumatic actuator

The Viking Pneumatic Actuator is a spring loaded, rolling diaphragm and piston operated valve. It is used to activate the deluge valve on and pneumatic releasing system (pilot line) loss of air.

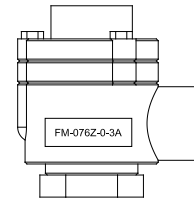

Alarm pressure switch

The alarm pressure switch monitors the water flow within the sprinkler piping. Should the Deluge Valve clapper opens to allow water to flow into the sprinkler piping. The alarm pressure switch will activate, indicating a water flow signal.

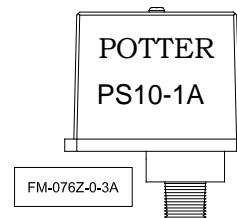

Optional mechanical equipment

❑ **Shut-off valve & sight glass option**

The Shut-off valve & sight glass option is intended to be used for applications where testing of the system operation without filling the sprinkler piping network is desirable and where it is critical that all functions of the system being tested under actual discharge conditions. Examples of such applications are freezers, ovens, museums, data processing and other hazards where the possibility of water leaking from the piping system is to be avoided at all costs.

Warning: Shut-off valve & sight glass option is **not available** on 8" systems.

❑ **Fire department connection**

The fire department connection option consists of a grooved tee fitting installed in lieu of the 90 degree elbow at the outlet of the deluge valve (A1). An access hole of the proper diameter is factory pre-drilled on the side of the **TOTALPAC®3** enclosures for connection of the piping going to the fire department connection.

Note: The fire department connection hardware itself (drain, Siamese, etc.) is **NOT** provided with this option and shall be provided by the installing contractor. Refer to NFPA-13 Standard for additional information about the equipment layout and installation.

Warning: Fire department connection is **not available** on 8" systems.

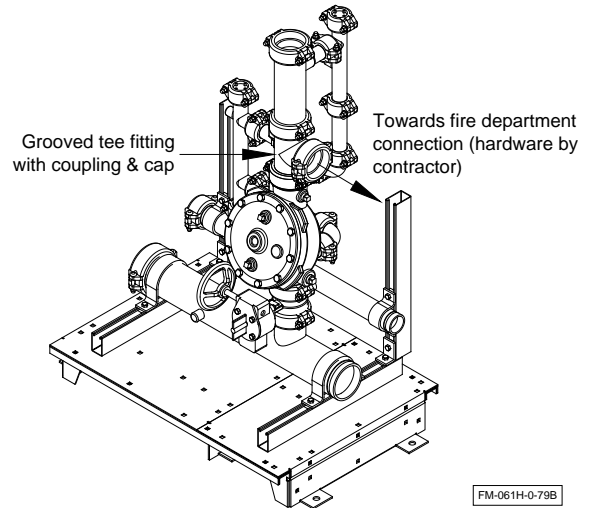
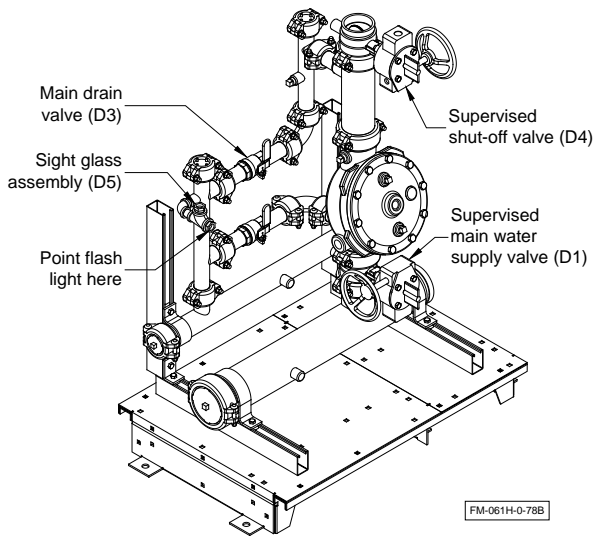

Optional mechanical equipment (continued)

❑ **Semi and full flange option**

When required by the user, TOTALPAC®3 units can be provided in either a semi-flanged or full flanged configuration.

The semi flanged option provides flanged fittings only on the water inlet pipe (side needs to be specified at the time of order) and on the system riser outlet. The drain manifold is then provided with a threaded end that also needs to have its side specified (left or right). The rest of the fittings are the same as usual with the main components being provided in the standard grooved-grooved configuration.

The full flanged option is the same as above but goes a step further with the main components being also provided with a flanged-flanged configuration.

When provided, the face of the flanges will always be situated 6 inches from the outside face of the mounting base or cabinet surface.

❑ **OSHPD option**

Pre-approved construction, under OSP-0341-10, using specific components.

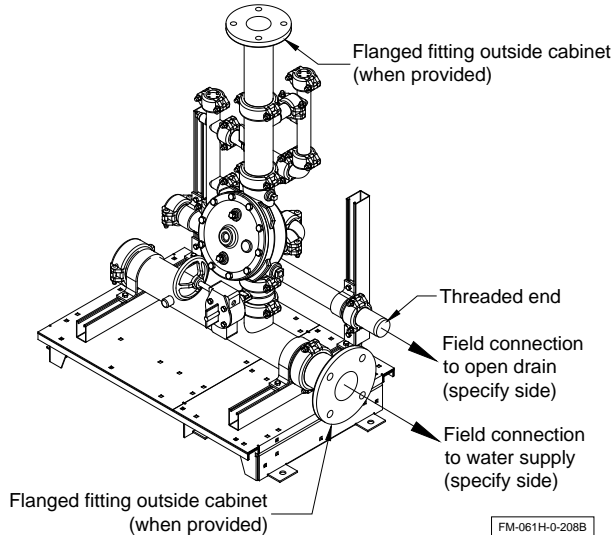

Air supply

□ **Air Pressure Maintenance Device (Style “C”)**

Used only for the pneumatic release piping network of pneumatically operated Preaction systems. An external air supply has to be provided by others (compressor, plant air or dry nitrogen cylinders) and piped to the air inlet port of the unit. Air supply style "C" provides an Air Pressure Maintenance Device (APMD) trim, factory mounted in the TOTALPAC®3 cabinet.

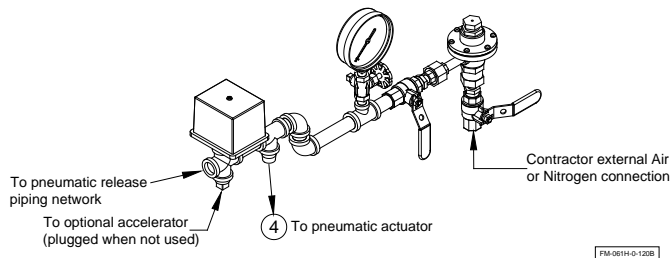

Details & field wiring diagrams

Cabinet with main components - Configuration without releasing control panel

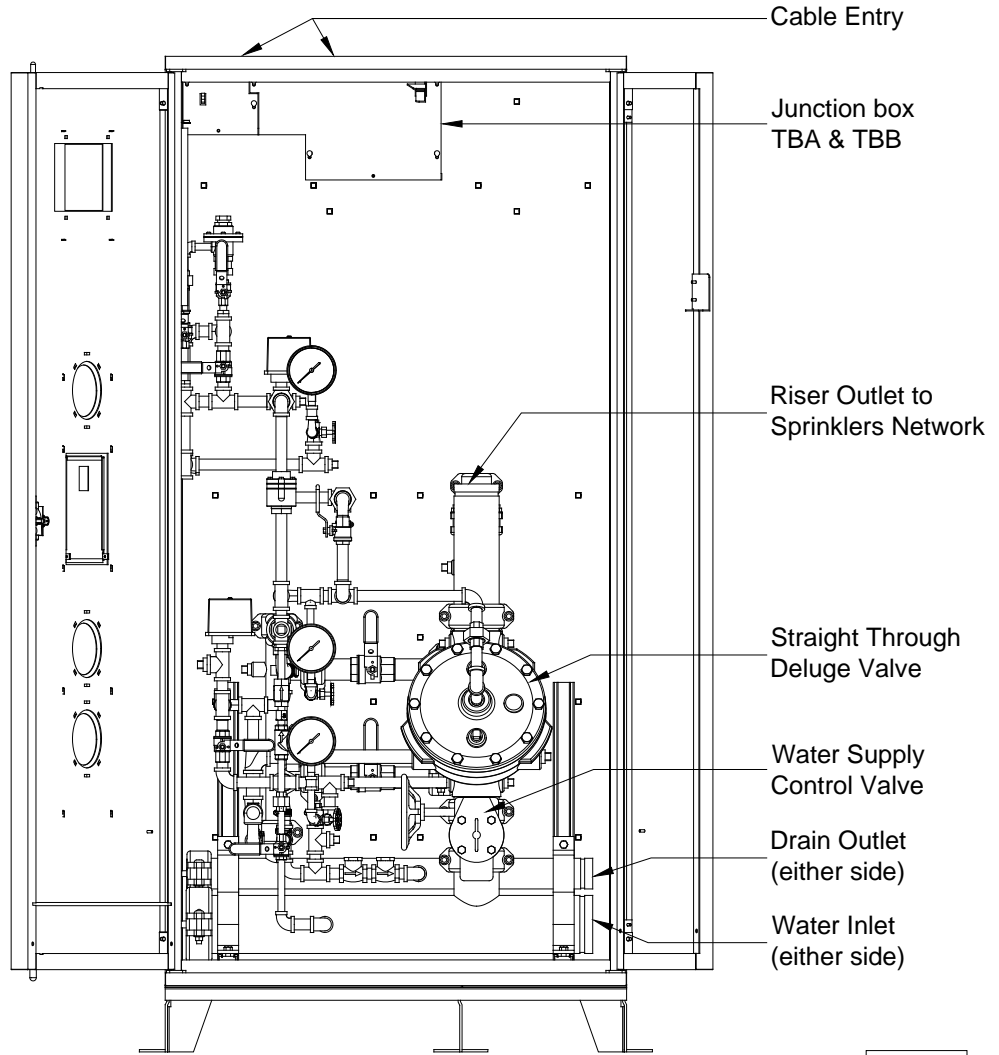

FM-061H-0-197B

Trim diagram

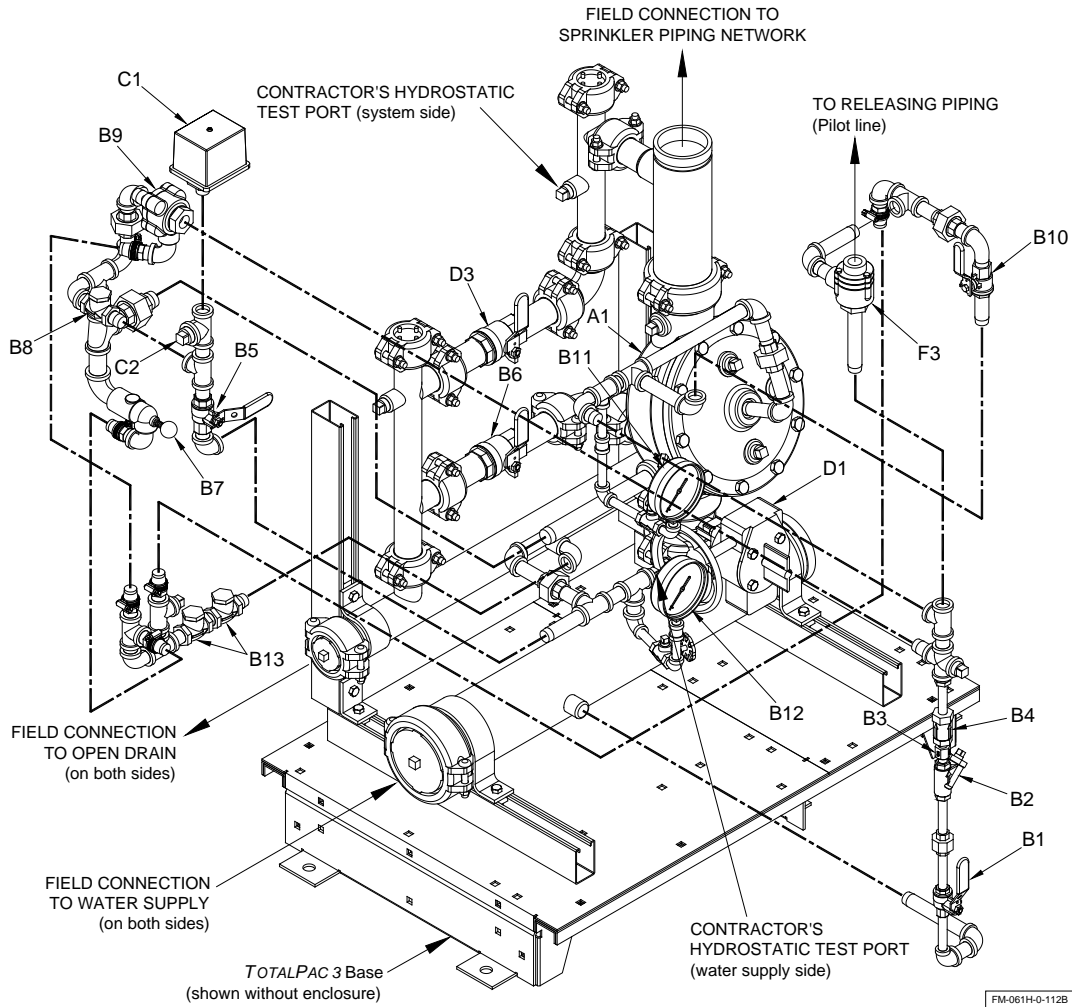

FM-061H-0-112B

Trim Components:

A1	Deluge valve	C1	Alarm pressure switch
B1	Priming valve	C2	Connection to water motor gong (strainer supplied by contractor)
B2	Strainer	D1	Water supply control valve
B3	1/16" Restricted orifice	D3	Main drain valve
B4	Spring loaded check valve	F3	Pneumatic actuator
B5	Alarm test valve		
B6	Flow test valve		
B7	Drip check valve		
B8	Drain check valve		
B9	Pressure operated relief valve (PORV)		
B10	Emergency release valve		
B11	Priming pressure water gauge & valve		
B12	Water supply pressure gauge & valve		
B13	Clapper check valve		

Field wiring diagrams:

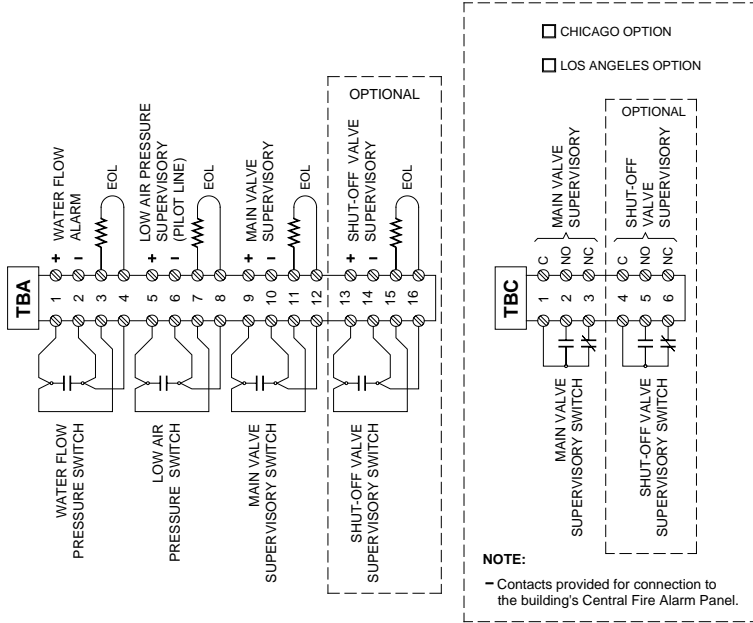

NOTES:

- All devices are factory wired.
- All devices are shown in their normal supervisory state.
- Contacts are rated:
Pressure switches: 2A, 30VDC 10A, 125/250VAC
Supervisory switches: 0.5A, 125VDC 0.25A, 250VDC 5A, 1/6HP, 125/250VAC
- Use dry contacts with power limited circuits only.
- EOL devices (not included) must be compatible with the Release Control Panel used.

FM-061H-0-95A

Dimensions and weights

Figure 1 – Cabinet dimensions:

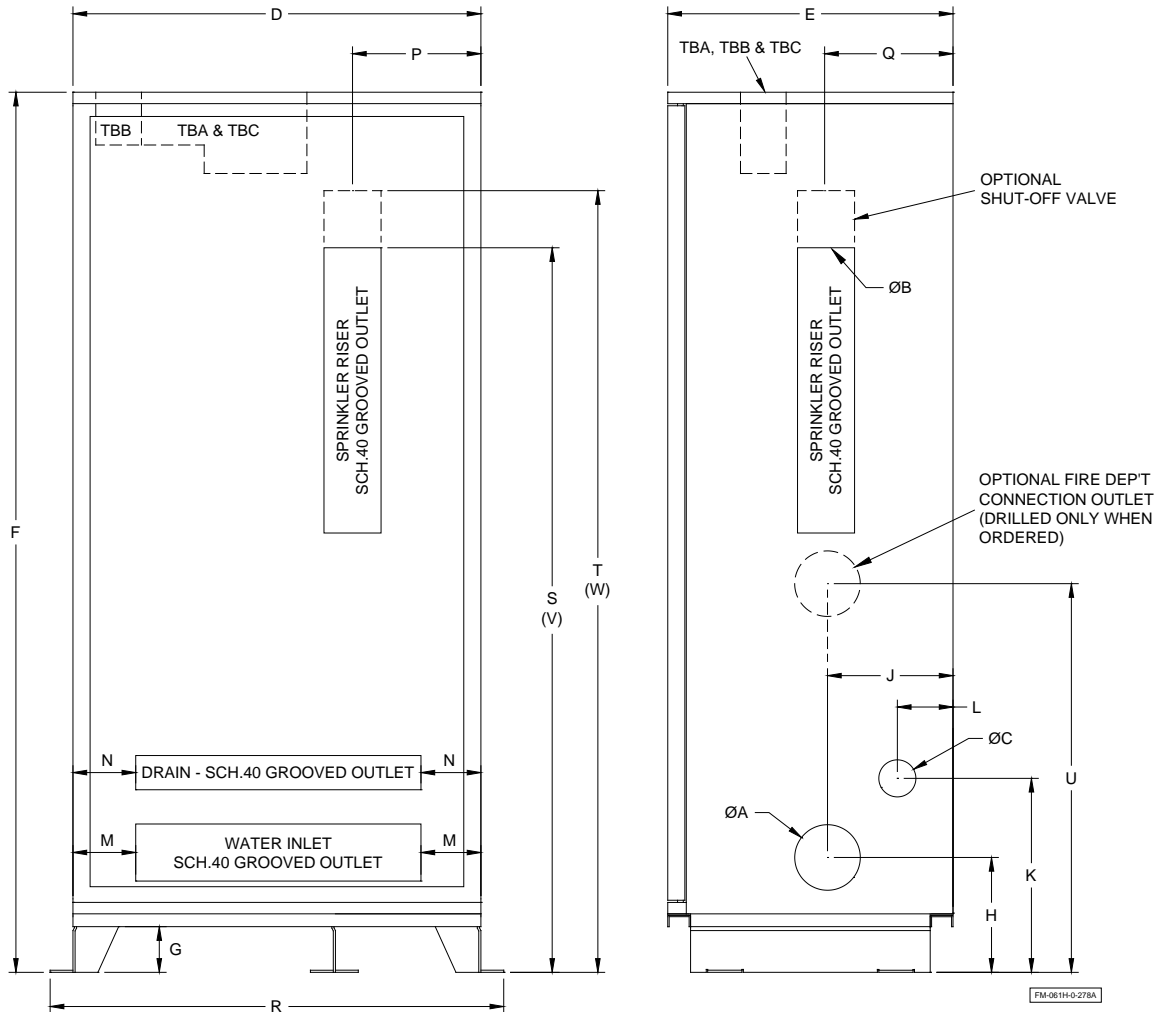

Table 1 - Cabinet dimensions - dimensions are in inches (mm)

Unit size	A	B	C	D	E	F	G	H	J	K	L	M	N	P	Q	R	S	T	U	V	W
1½" (40)	2" (51)	1½" (38)	2" (51)	23" (584)	25" (635)	77" (1956)	4" (102)	8¾" (222)	11½" (292)	13¾" (349)	3¾" (95)	2¾" (70)	2¾" (70)	8" (203)	11½" (292)	27" (686)	43" (1092)	47" (1194)	34¼" (870)	48½" (1232)	52½" (1334)
2" (50)	2" (51)	2" (51)	2" (51)	23" (584)	25" (635)	77" (1956)	4" (102)	8¾" (222)	11½" (292)	13¾" (349)	3¾" (95)	2¾" (70)	2¾" (70)	8" (203)	11½" (292)	27" (686)	45¼" (1149)	49¼" (1251)	34¾" (883)	51¾" (1314)	55¾" (1232)
3" (80)	4" (102)	3" (76)	2" (51)	35¾" (908)	25" (635)	77" (1956)	4" (102)	10" (254)	11½" (292)	13¾" (349)	3¾" (95)	2¾" (70)	2¾" (70)	11¾" (298)	11½" (292)	39¾" (1010)	44" (1118)	47¾" (1213)	37" (940)	51" (1295)	54¾" (1391)
4" (100)	4" (102)	4" (102)	2" (51)	35¾" (908)	25" (635)	77" (1956)	4" (102)	10" (254)	11½" (292)	13¾" (349)	3¾" (95)	2½" (64)	2½" (64)	12" (305)	11½" (292)	39¾" (1010)	48½" (1232)	53¼" (1353)	42" (1499)	56½" (1435)	61¼" (1556)
6" (150)	6" (152)	6" (152)	2" (51)	46" (1168)	25" (635)	77" (1956)	4" (102)	11" (279)	11½" (292)	13¾" (349)	3¾" (95)	5¼" (133)	5¼" (133)	17¾" (451)	11½" (292)	50" (1270)	59½" (1511)	65¼" (1657)	51½" (1308)	70½" (1791)	76¼" (1937)
8" (200)	8" (203)	8" (203)	2" (51)	54" (1372)	31" (787)	81" (2057)	4" (102)	12" (305)	13¾" (337)	17" (432)	3¾" (95)	9" (229)	6¾" (171)	27" (686)	13¾" (337)	58" (1473)	70" (1778)	75¼" (1911)	N/A	N/A	N/A

Notes:

1. Dimensions are nominal and may vary ±¼" (±5mm).
2. Dimensions U, V & W are for optional fire department connection.

Figure 2 - Floor anchoring dimensions

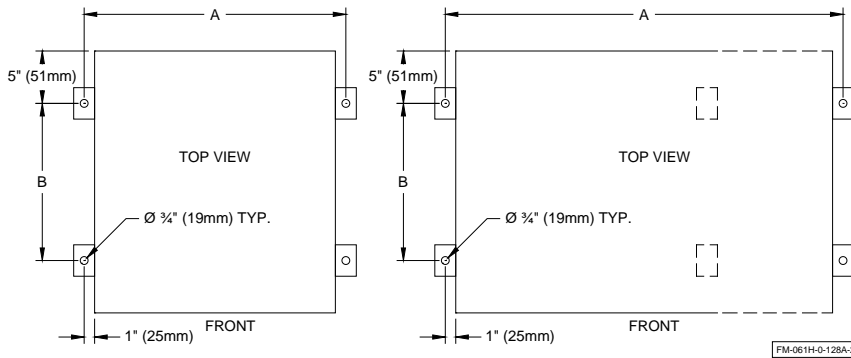

Table 2 - Floor anchoring dimensions

Unit size	A	B
1½" (40mm)	25" (635mm)	15" (380mm)
2" (50mm)	25" (635mm)	15" (380mm)
3" (80mm)	37¾" (959mm)	15" (380mm)
4" (100mm)	37¾" (959mm)	15" (380mm)
6" (150mm)	48" (1220mm)	15" (380mm)
8" (200mm)	56" (1422mm)	21" (530mm)

Figure 3 - Cabinet & doors clearance detail

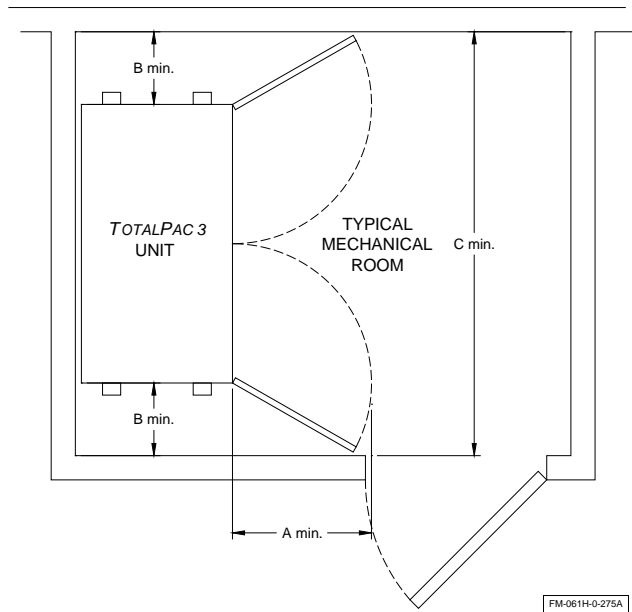

Table 3 - Cabinet clearance dimensions

Unit size	A	B	C
1½" (40mm)	24" (610mm)	12" (305mm)	48" (1219mm)
2" (50mm)	24" (610mm)	12" (305mm)	48" (1219mm)
3" (80mm)	24" (610mm)	12" (305mm)	60" (1524mm)
4" (100mm)	24" (610mm)	12" (305mm)	60" (1524mm)
6" (150mm)	24" (610mm)	12" (305mm)	70" (1778mm)
8" (200mm)	32" (813mm)	12" (305mm)	78" (1981mm)

Note : Minimum dimensions are according to door clearance and external piping requirements.

Figure 4 - Knockouts details

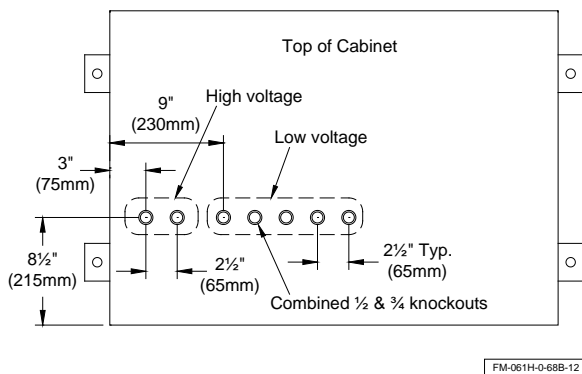
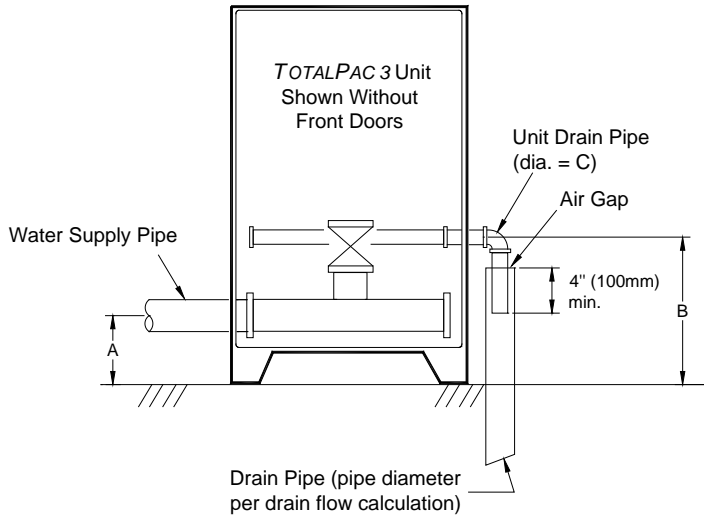

Table 4 - System weight in cabinet

System size	Weight ¹
1½" (40mm)	450 lb (204 kg)
2" (50mm)	455 lb (206 kg)
3" (80mm)	690 lb (313 kg)
4" (100mm)	705 lb (320 kg)
6" (150mm)	1010 lb (458 kg)
8" (200mm)	1470 lb (668 kg)

Figure 5 - Open drain details for single unit



FM-061H-0-139A

Table 5 - Manifold dimensions

Unit size	A	B	C
1½" (40mm)	8¾" (222mm)	13¾" (350mm)	2" (50mm)
2" (50mm)	8¾" (222mm)	13¾" (350mm)	2" (50mm)
3" (80mm)	10" (255mm)	13¾" (350mm)	2" (50mm)
4" (100mm)	10" (255mm)	13¾" (350mm)	2" (50mm)
6" (150mm)	11" (280mm)	13¾" (350mm)	2" (50mm)
8" (200mm)	12" (305mm)	17½" (445mm)	2" (50mm)

Figure 6 - Open drain details for multiple units
(refer to dimensions in table 5)

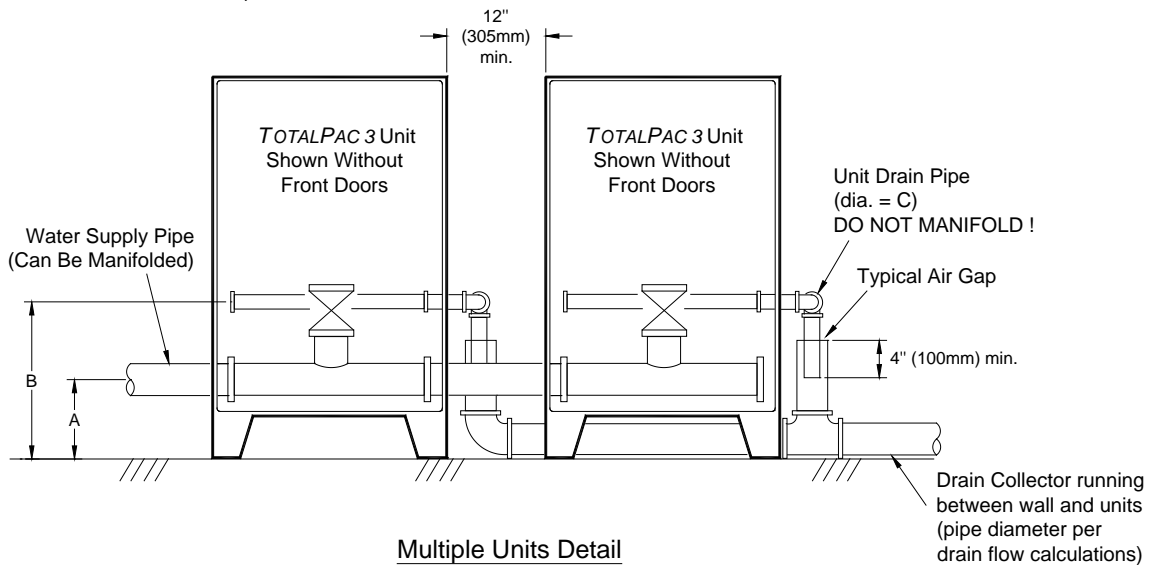

FM-061H-0-140A

Notes:

1. Water supply and drain pipes can be connected on either sides of cabinet.
2. All pipes and fittings should meet applicable codes.
3. Actual drain collector diameter shall be determined with detailed hydraulic calculations and is the responsibility of the system designer.



ADVANCED INTEGRATED FIRE PROTECTION SYSTEMS

1935, Lionel-Bertrand Blvd.
Boisbriand QC Canada J7H 1N8
Tel.: 450-437-3473 • Fax: 450-437-1930
Toll Free: 866-347-3353
Email: info@fireflex.com • Web: www.fireflex.com

Copyright © 2019 FireFlex Systems Inc.

All Rights Reserved

While all reasonable efforts have been taken in the preparation of this datasheet to assure its accuracy, FireFlex Systems Inc assumes no liability resulting from any errors or omissions in this datasheet, or from the use of the information contained herein.

FireFlex Systems Inc. reserves the right to make changes to this datasheet herewith at any time, without prior notification.

TOTALPAC® is a registered trademark of FireFlex Systems Inc.