



DESCRIPTION

Foam concentrate is stored inside a normally non-pressurized stainless steel pressure vessel type tank (T1) stamped according to ASME Section VIII Div. 1. Storage tank maximum working pressure is 150 psi (1033 kPa). The tank is supplied with a safety relief valve (T8) set at 135 psi (930 kPa) for protection against over-pressurization. Foam storage tank is factory assembled and includes all the valves, trim and hardware as shown on Figure 1. Manual valves are provided to fill the tank (T9) with foam concentrate and to release the air pressure (T6) after a CAF discharge. A sight gauge (T5) is also provided to allow visual verification of the tank foam concentrate normal level.

Foam concentrate

CAF system shall be used with the following foam concentrates and concentrations:

Foam concentrate	Concentration
<i>Hydrocarbons</i>	
Ansul Ansulite 3X3 LV	2%
Ansul Ansulite 3X3 LV	2%
<i>Polar Solvents</i>	
Ansul Ansulite 3X3 LV	6%

Shelf Life

The shelf life of any foam concentrate is maximized by proper storage conditions and maintenance. Factors affecting shelf life are wide temperature changes, extreme high or low temperatures, evaporation, dilution, and contamination by foreign materials. Properly stored foam concentrates have been tested and shown no significant loss of firefighting performance, even after 15 years. For further details, see the Foam Concentrate Data Sheet.

Environmental and Toxicological Information

Foam concentrate used with Compressed Air Foam Systems are biodegradable. However, as with any substance, care should be taken to prevent discharge from entering ground water surface water, or storm drains. Since facilities vary widely by location, disposal should be made in accordance with federal, state and local regulations. For further details, see the foam Concentrate Data Sheet and Material Safety Data Sheet.

Foam tank design and selection

The capacity established at the design stage is based on both the maximum system flow and discharge time required for the largest single hazard protected or group of hazards that are protected simultaneously; FireFlex's design software will take that into account when calculating the system's capacity.

Interconnection Piping to ICAF System

There are two interconnections lines provided on all foam storage tanks. One connection is used to pressurize the foam storage tank with compressed air (item 3), the other to provide foam concentrate to the mixing chamber (item 2). Piping between the foam storage tank and the ICAF System is factory prepared according to installation arrangement and is supplied with the system.

Storage tank dimensions & capacity:

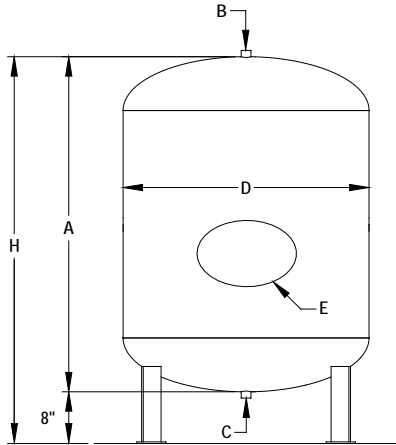

Nominal Capacity USGal	Dimensions (in)			Outlet (NPTF)		Manhole
	A	D	H	B	C	
15	50	11	N/A	1	1	N/A
25	35	16	43			
35	23	24	31			
50	33	24	41			
75	46	24	54			
100	64	24	72	2	1	N/A
150	44	36	52			
200	54	36	62			
300	67	38	75			
400	63	48	71			
450	69	48	77	3 flange	1	16 X 12
500	65	54	73			

Note: 15 gallon tank is supported by brackets

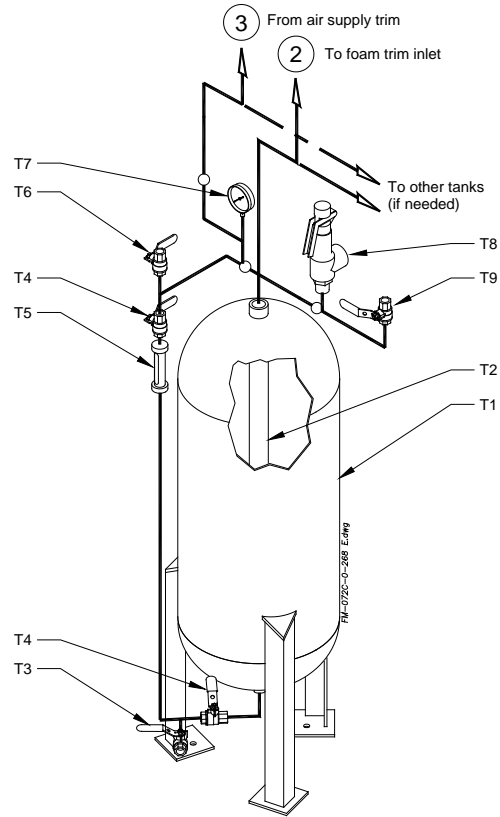

- Foam storage tank components:**
- T1 Foam storage tank
 - T2 Dip tube
 - T3 Storage tank drain valve
 - T4 Level sight gauge isolation valve
 - T5 Foam level sight gauge
 - T6 Foam refill vent valve
 - T7 Pressure gauge
 - T8 Pressure safety valve
 - T9 Foam refill valve

FIREFLEX Systems Inc.
1935, Lionel-Bertrand Blvd.
Boisbriand, Quebec
Canada J7N 1N8
Toll Free: (866) 347-3353
Website: www.fireflex.com