



DESCRIPTION

Compressed Air Foam is constituted of 90% compressed air. Air is provided by DOT and TC certified compressed air cylinders (V2) pressurized to 2400 psi (16,536 kPa). Each cylinder is supplied with a cylinder valve (V4) equipped with a safety relief disc (V3) which provides relief at 3600-4000 psi. Air pressure regulators (V5) are used to reduce the air pressure to a working pressure of 100 psi (689 kPa) for the system operation.

The cylinders bank pressure is supervised by a pressure transducer (V7) sending a low pressure supervisory signal when the pressure goes under the minimum pressure required to provide air supply for the specified discharge time. A safety valve (A2 - mounted in the cabinet) is also used at the outlet of the air pressure regulator (V5) to protect the system from high pressure in case of malfunction. The maximum air operating pressure on the system side (downstream of the air regulator) is adjusted to 135 psi (930 kPa).

The cylinders bank is factory assembled on a painted steel skid and includes all the high pressure tubing, manifold (V8) and hardware.

Cylinder valve guards are used instead of cylinder caps, eliminating the repetitive costs associated with the use of cylinder caps. Cylinder valve guards protect the cylinder heads during shipment, therefore no protective caps have to be removed and most importantly, no tubing or fittings are required to be installed after receiving.

The cylinders bank manifold is also provided with a refilling port (V9) which allows refilling the complete bank on-site with a high pressure compressor, without having to remove any other parts or having to transport the cylinders to a filling plant. The skid mounted cylinders bank is available with single or twin pressure regulator (V5) assemblies and is available in the following storage capacities:

- 9 up to 2 cylinders
- 9 up to 4 cylinders
- 9 up to 6 cylinders
- 9 up to 8 cylinders
- 9 up to 10 cylinders

Air supply design and selection:

The number of cylinders (V2) and regulators (V5) established at the design stage is based on both the maximum system flow and discharge time required for the largest single hazard protected or group of hazards that are protected simultaneously. FireFlex hydropneumatic software will take that into account when computing the system capacity.

Note regarding air cylinders: The quantity of compressed air cylinders is calculated based on a storage temperature of 70°F (21°C), with a range of 60°F to 80°F (15.5°C to 26.6°C). Storage temperatures outside this range must be taken into consideration during the system design stage.

Interconnection Piping to ICAF System

There is one interconnection line (circled item #4) provided on every air cylinder bank. The connection is used to supply compressed air between the cylinders bank and the ICAF System. The piping is factory prepared according to installation arrangement and is supplied with the system.

Cylinders Approvals:

D.O.T.: 3AA2300
T.C.: 3AAM176

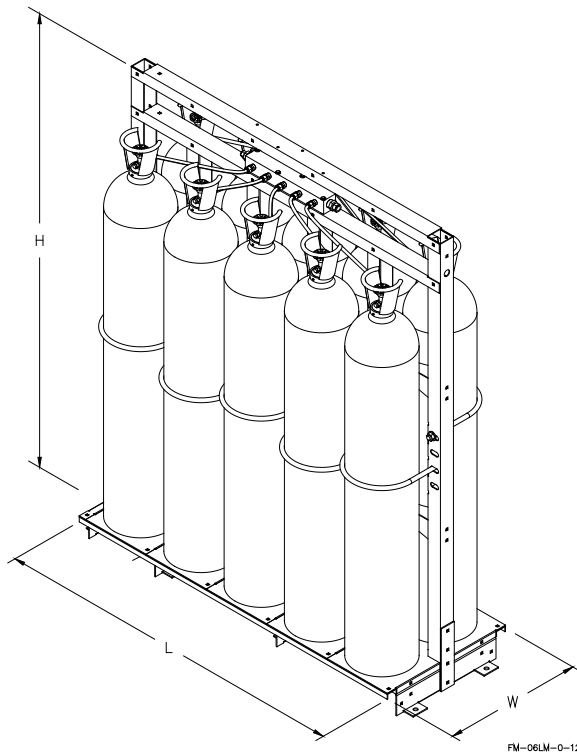

FM-06LM-0-12

Figure 1 – Compressed Air Cylinder Bank

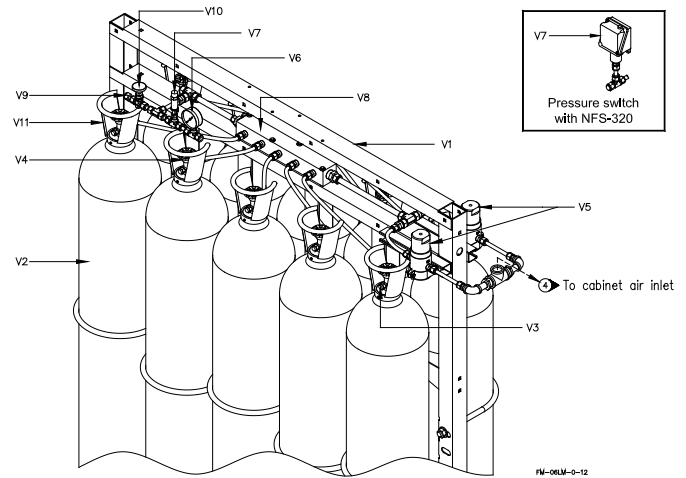

FM-06LM-0-12

Air supply Components:

- V1 Cylinder rack
- V2 Compressed air cylinders
- V3 Safety release disk
- V4 Cylinder valve
- V5 Pressure regulator
- V6 Pressure gauge
- V7 Pressure transducer
- V8 High pressure manifold
- V9 Refilling outlet
- V10 High pressure isolation valve (option)
- V11 Valve guards

Cylinders Bank Dimensions & Capacity:

Storage Capacity (Qty of cyls.)	Dimensions (inches)		
	Width (W)	Length (L)	Height (H)
2	25	14½	82¼
4		27¼	
6		40	
8		52¼	
10		65¼	

Note: Add 2" on both sides to the "L" Dimension to allow for the floor anchor angles.

FIREFLEX Systems Inc.

1935, Lionel-Bertrand Blvd.
Boisbriand, Quebec
Canada J7N 1N8
Toll Free: (866) 347-3353
Website: www.fireflex.com